

DIGIWAY PTY LTD

SW50-2 Dual Swing Gate Motor INSTRUCTION MANUAL



COMPLIANCE CERTIFICATE

Client Details: Customer: Digiway Pty Ltd
Address: 11A Ganton Ct, Williamstown, VIC, 3016
Contact: Xihe SHI
Phone: (+61) (03) 99738999
Email: digiway@digiway.com.au

Product Details: Device: Swing Gate Motor
Model: SW50-2
Serial: N/A

Reference Standard: **AS/NZS 61000.6.3: 2021:**
Electromagnetic compatibility (EMC) Generic standards - Emission standard for residential environments (IEC 61000-6-3:2020 (ED 3,0) MOD),

Test Methods: CISPR 16-1-4: 2010 Amd1: 2012
CISPR 16-2-3: 2010 Amd1: 2010, Amd2: 2014

Test Date: 22nd June 2023

Tests Performed by: Abdirahman Dacar
Compliance Engineering Pty Ltd
90 Indian Drive,
Keysborough, Victoria, Australia 3173,
Telephone: +61 3 9763 3079
Email: info@compeng.com.au

The Swing Gate Motor (SW50-2) complied with RF emission requirements detailed in AS/NZS 61000.6.3: 2021, Electromagnetic compatibility (EMC) Generic standards - Emission standard for residential environments.

		27 th June 2023
Prepared: Abdirahman Dacar Test Engineer Compliance Engineering Pty Ltd	Approved: Andrew Burdon Technical Manager Compliance Engineering Pty Ltd	Date

This test report is not to be reproduced except in full, without written approval from Compliance Engineering Pty Ltd.

MAIN FEATURES

1. General Descriptions and features

1.1 General descriptions

It is recommended reading and understanding this manual before start to install the control board. Some features and idea are new. So, take some time to read through the manual to get better understanding of the board. That will save your time during installation and get the best benefit from the control board.

1.2 General features

SW50 is designed for most of domestic swing gate. It can be mounted on brick wall/pier or steel post. The arm supplied can be met most of application situations. If special need, customer can modify arm or ask supplier/dealer to contact manufacturer for different arm.

Before installation must check:

- A) Gate moves freely by hand without any difficulty in either open and closing directions.
- B) The post or pier must be strong enough.
- C) Gate must have open and closed stopper
- D) 240V 10A power point must be available within one metre of the post/pier
- E) If there is not enough side room, minimum side room requirement see following drawing.

2. Motor installation

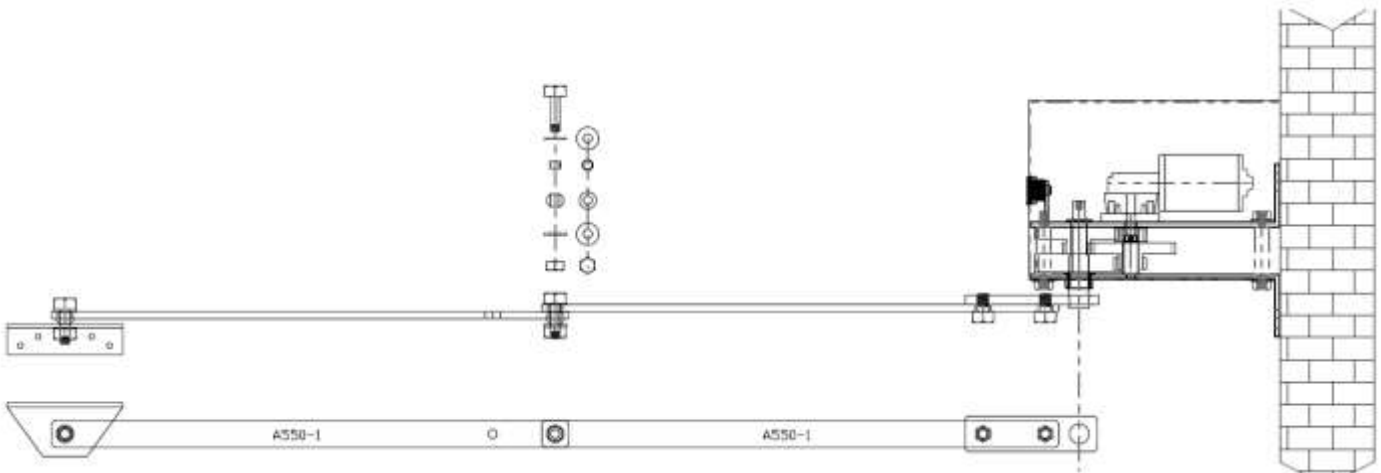

Two arms are the exactly same. For different gate or different application, can cut the arm to the required length to suit the gate.

GATE MOTOR MOUNTING

Closed Position

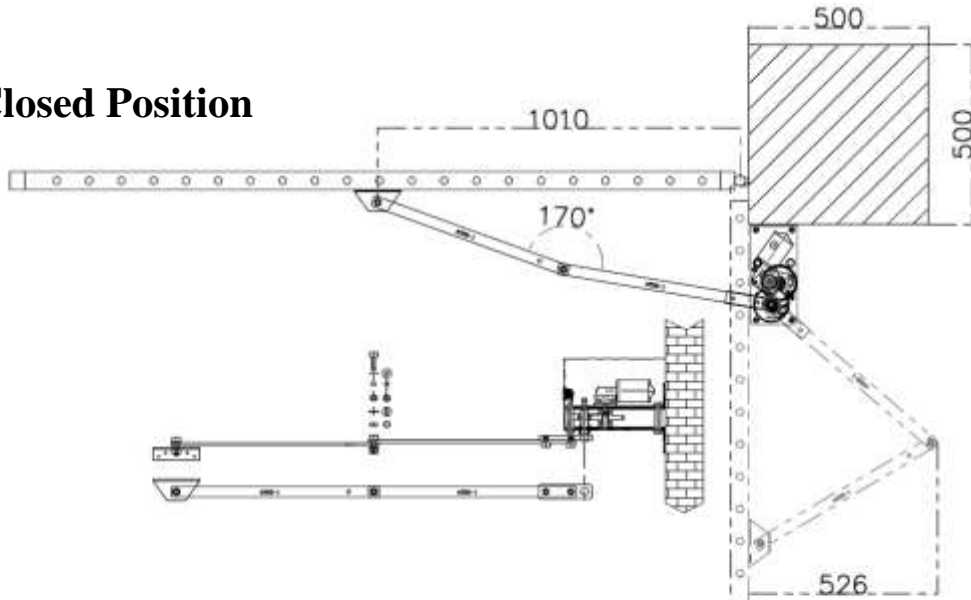

Opened position

Standard installation for brick post

Closed Position

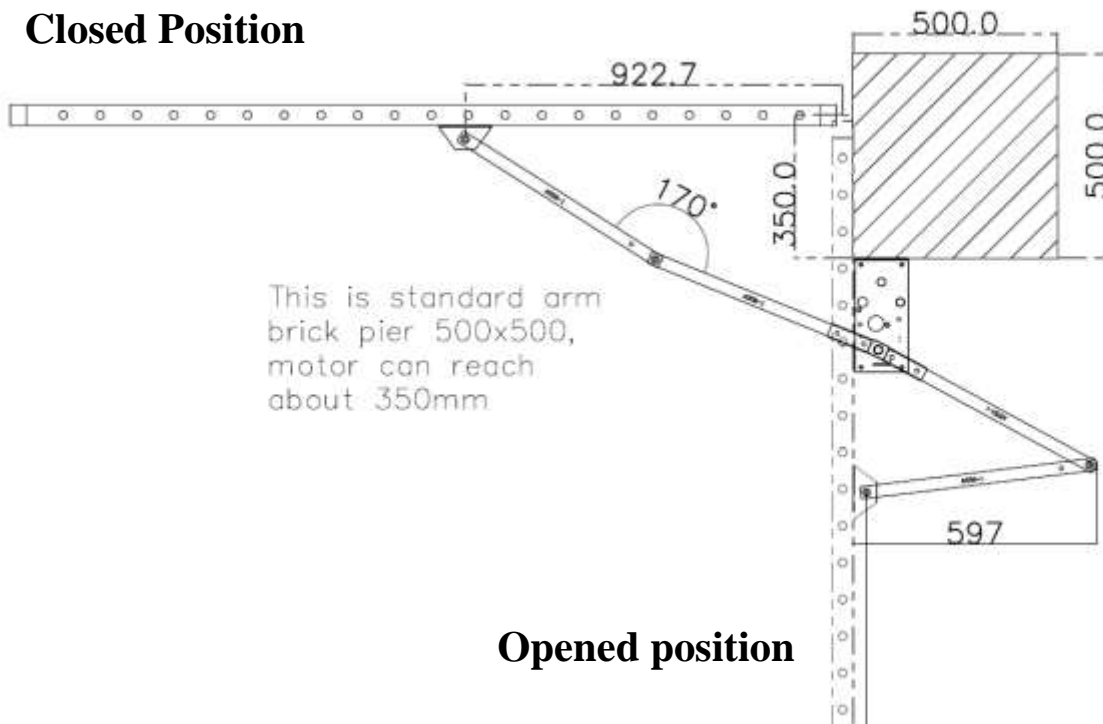

Opened position

Gate Swing in

Closed Position

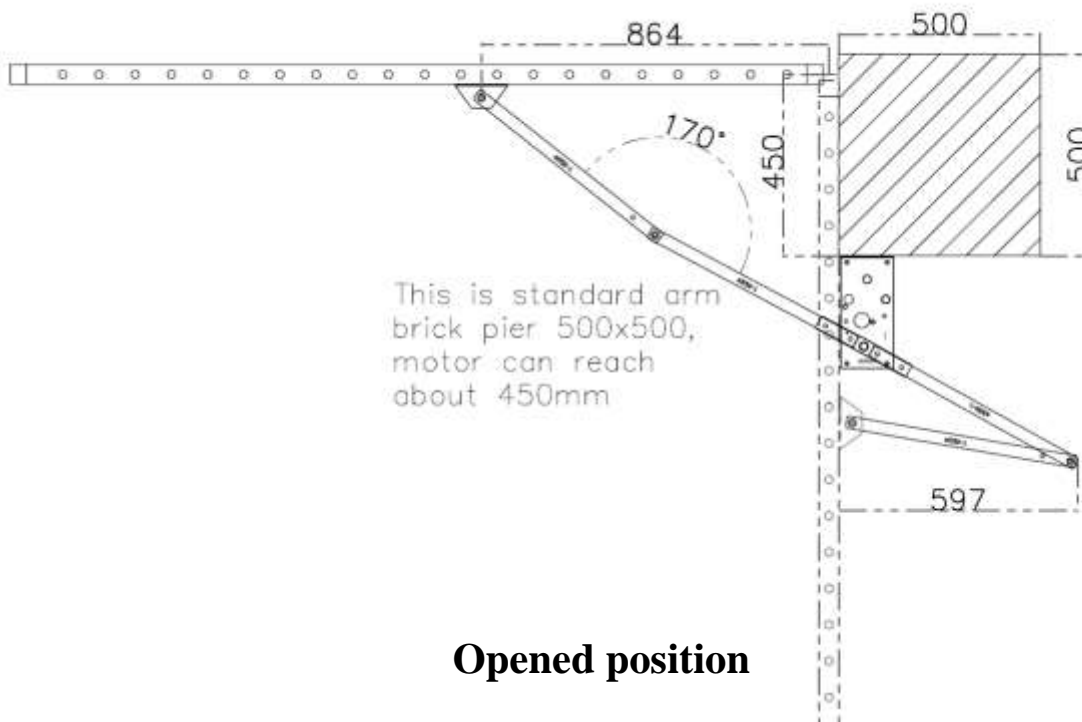

Opened position

Gate swing in

Opened position

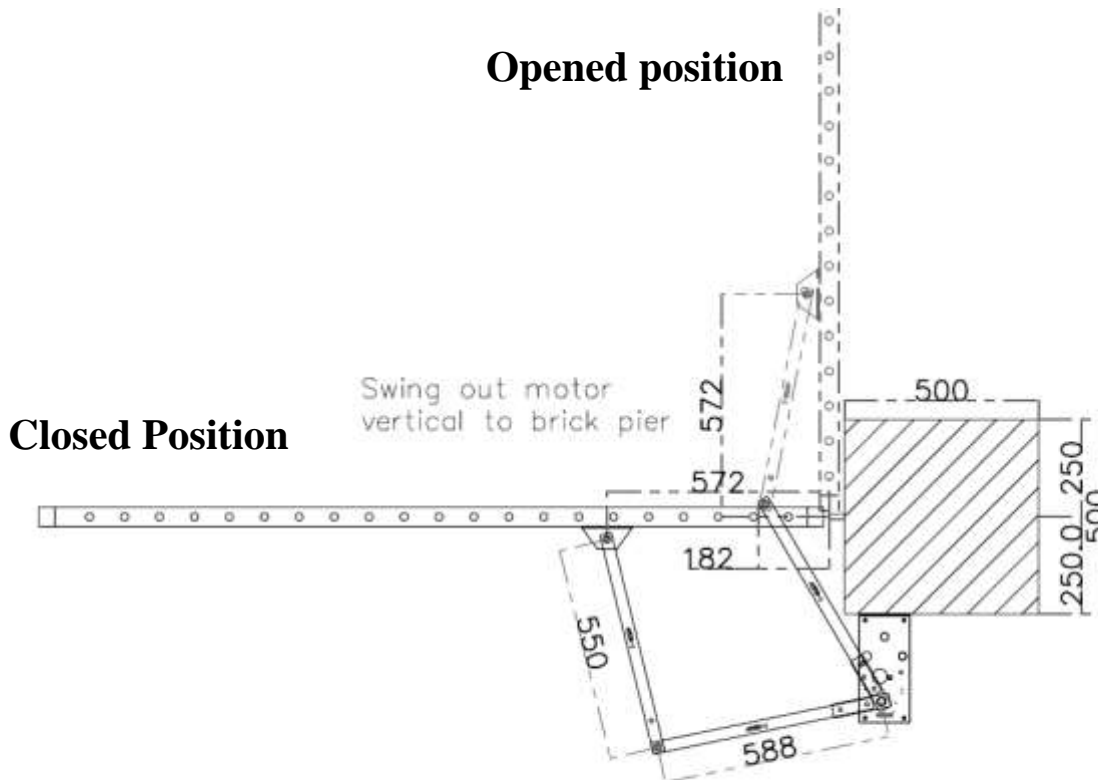

Closed Position

Opened position

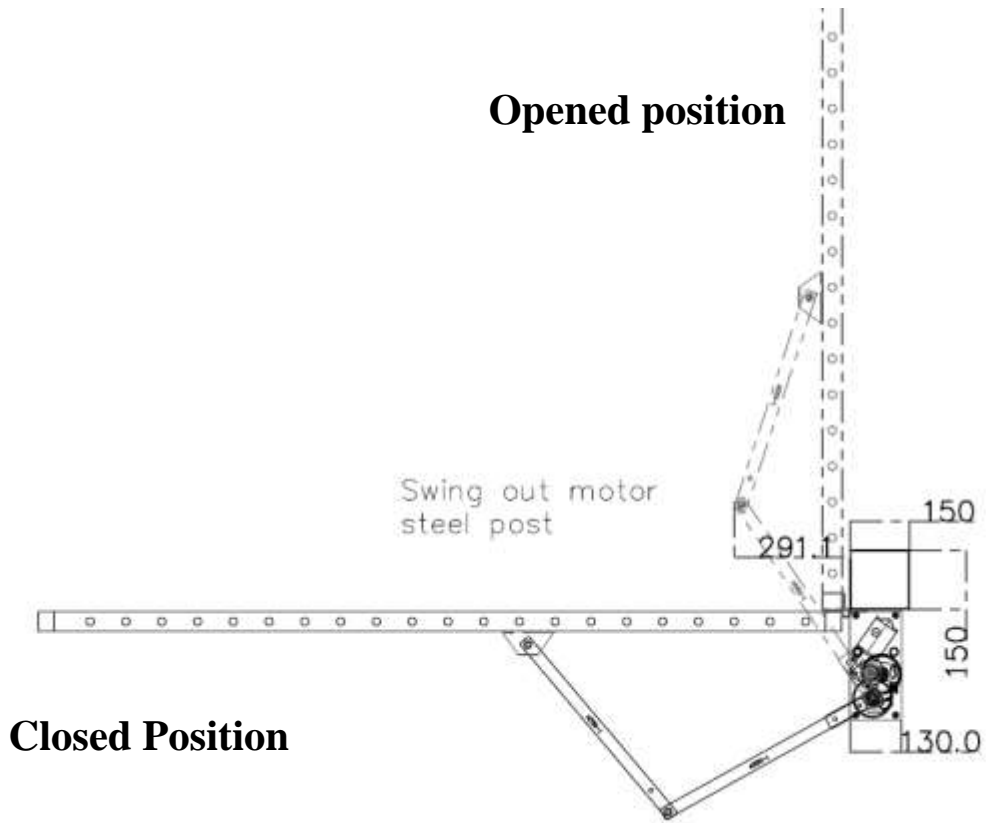

Closed Position

Brick Post, Gate Swing Out

Steel Post, swing out application

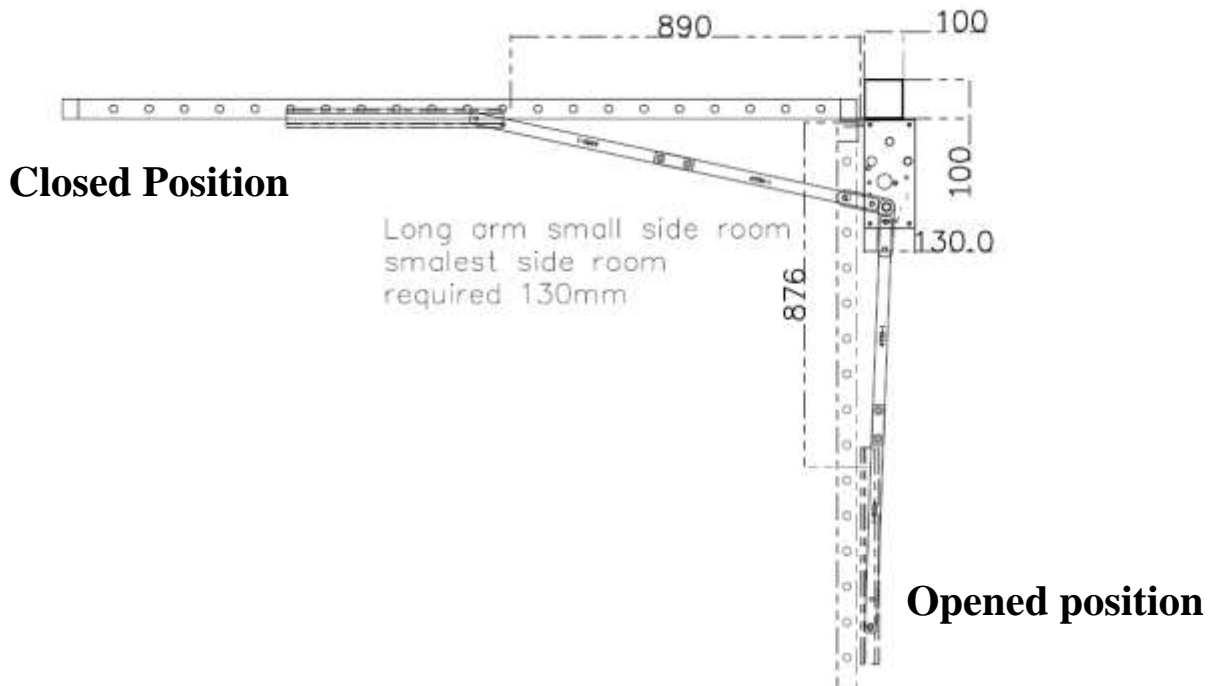

Steel Post, small side room, swing in with special parts

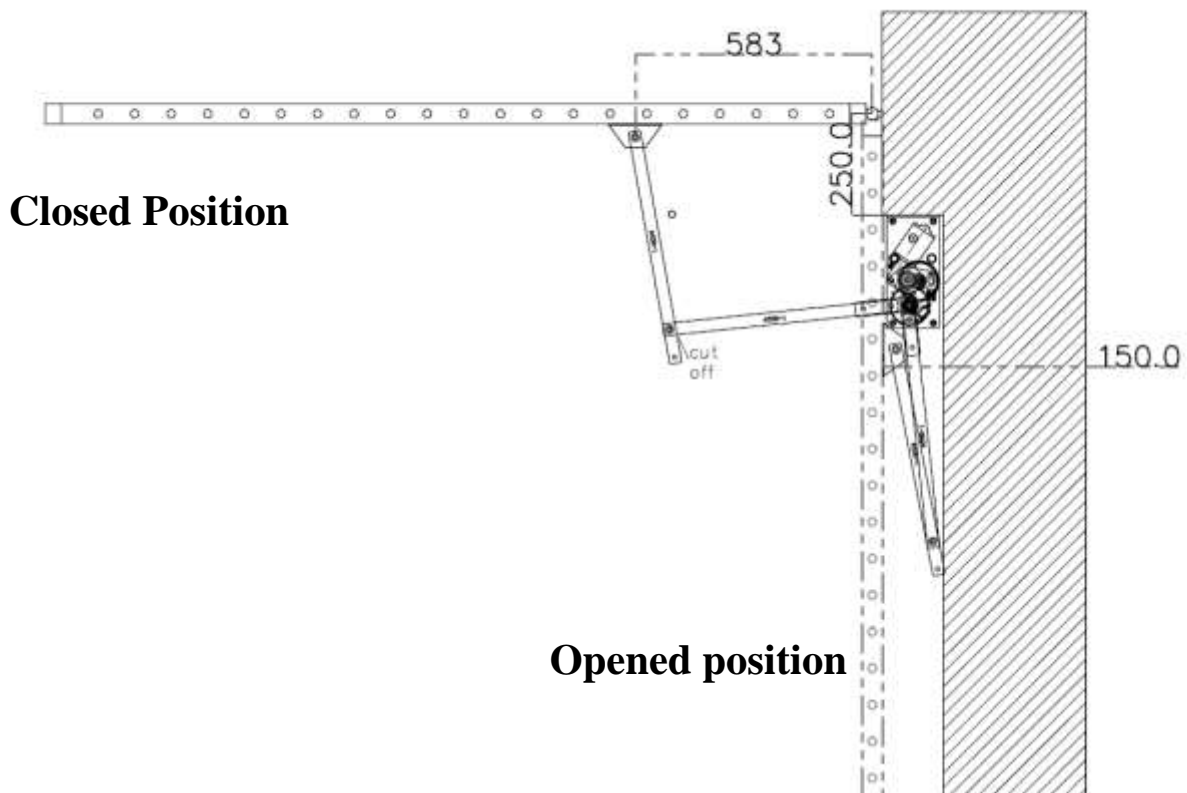

Closed Position

Opened position

Opened position

Special limited side room, cut the arm to suit the application

Manual Release

Engaged position

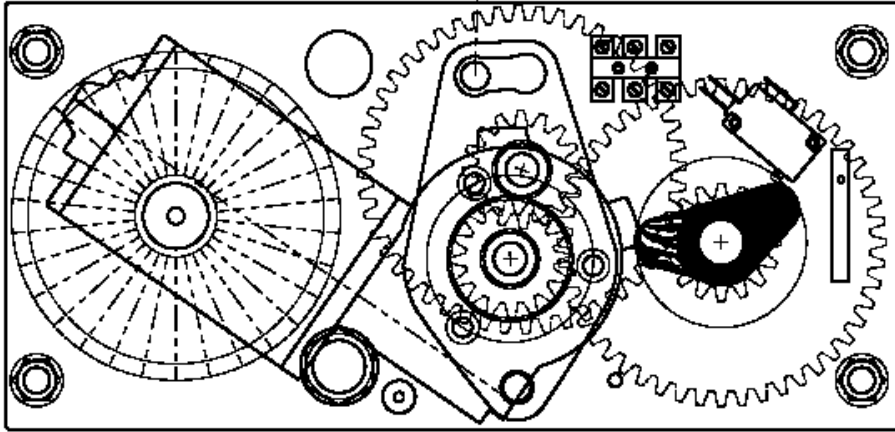

Disengaged position

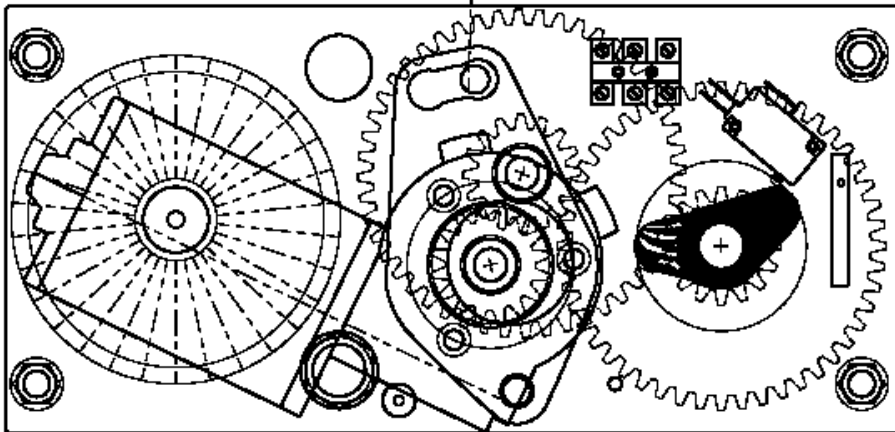

- 1) Anticlockwise push handle.
- 2) push handle to the position.
- 3) Push motor up and left direction. NOW GATE IS FREE TO MOVE.
- 4) Push motor down and right direction. Make sure gears engaged.
- 5) push manual release handle clockwise and clock the gear.

GATE MOTOR CONTROLLER

3. Control board

The SW50-2 swing gate motor controlled by DC2 control board, which has following features:

- Control one or two 12 or 24V DC motors. For Swing gates, Sliding Gates, Roller shutter doors etc.
- Limit switch inputs, N/C or N/O
- Lock or lights relay output.
- Adjustable timers: auto close time and PE trig auto close time.
- Pedestrian cycle
- Safety control inputs.
- Self-learn soft start and soft stop.

View of Control board

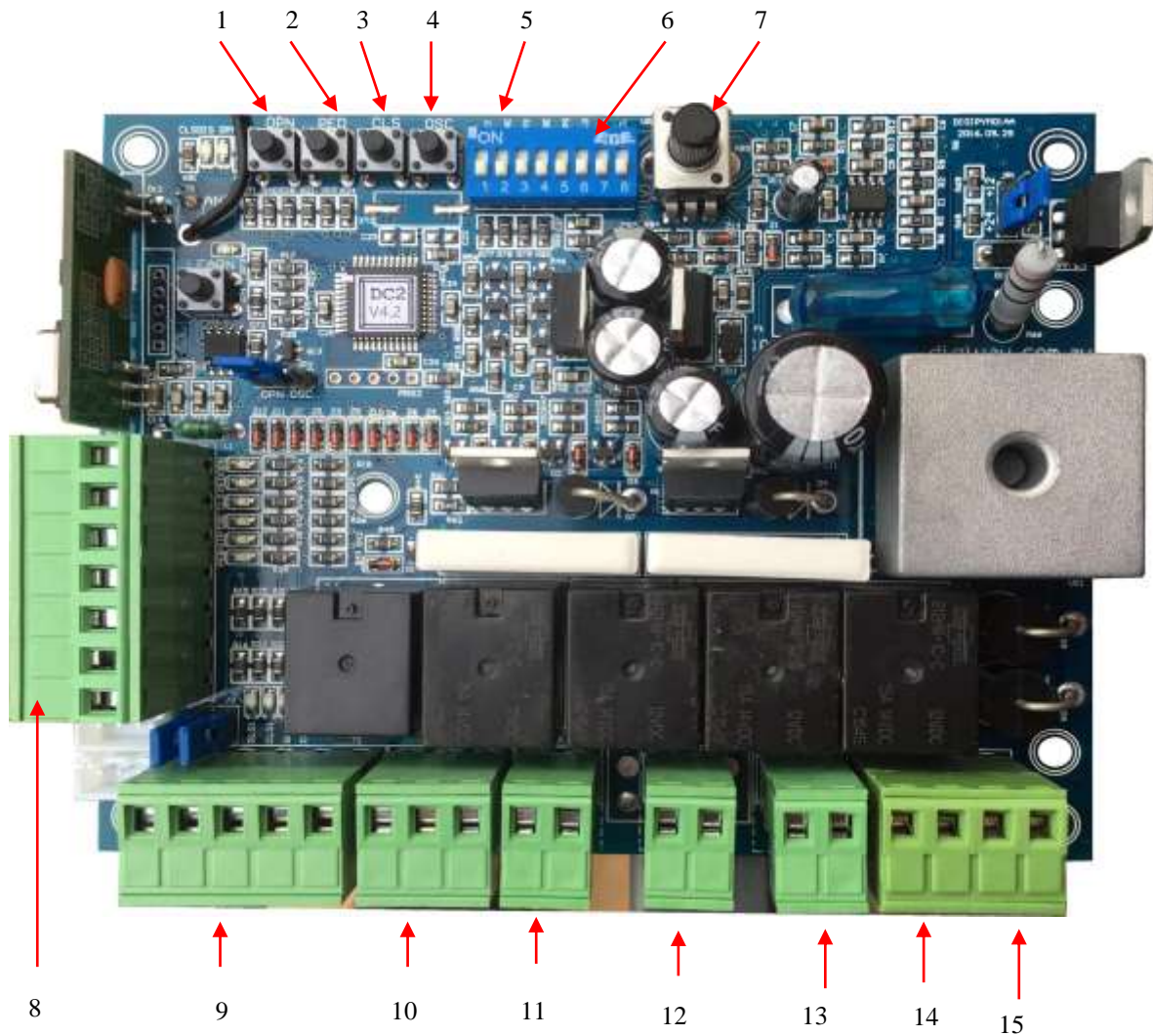
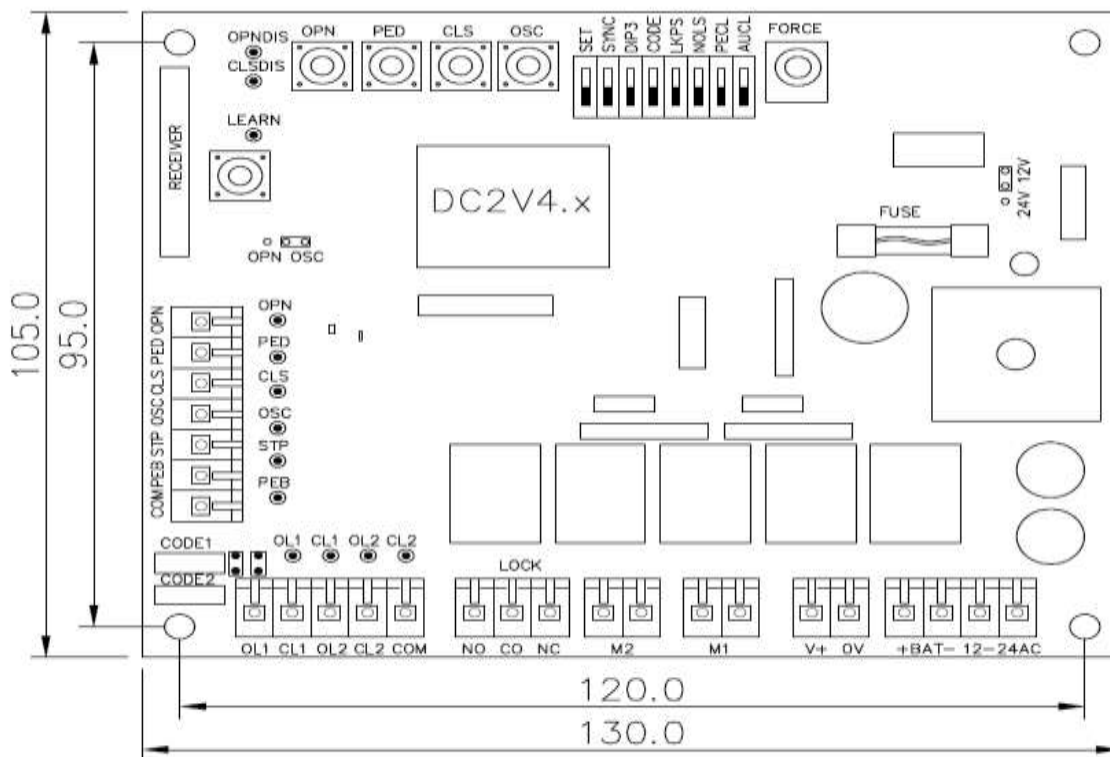

Fig. 9 DC2 PCB

GATE MOTOR CONTROLLER

1. OPN open push button
2. CLS close push button
3. PED pedestrian open push button
4. OSC Open, Stop, Close push button
5. Gate status display, open green, close red
6. Mode selection DIP switch
7. Close motor force (reverse power)
8. Control inputs terminals.
9. Limit switch input
10. Lock output relay
11. M1 output
12. M2 output
13. Accessories power 14VDC or 26VDC depending the transformer voltage
14. Battery terminals
15. Power supply 12 V or 24V AC.

3.1 Control inputs



CONTROLLER SETTINGS

DC2 PCB dimensions and mounting holes

Control Terminals

- OPN ----- N/O open input.
- PED ----- N/O pedestrian open push button, only open motor-1
- PEB ----- N/C photo electrical beams
- OSC ----- N/O Open – Stop – Close--Open
- OL1 ----- Motor 1 open limit switch, N/C or N/O selected by DIP4
- CL1 ----- Motor 1 close limit switch, N/C or N/O selected by DIP4
- OL2 ----- Motor 2 open limit switch, N/C or N/O selected by DIP4
- CL2 ----- Motor 2 close limit switch, N/C or N/O selected by DIP4

Buttons

- OPN button ---- Full (M1&M2) open gate and used for settings
- PED button ----- Ped (M1) open gate and used for settings
- CLS button ----- CLS gate and used for settings
- OSC button ----- Open – Stop – Close—Open and for setting

3.2 DIP Switch Settings

- | | | | |
|----------|------|-----------------------------|-----------------------------|
| DIP1---- | SET | ON—set, | OFF – Run |
| DIP2---- | SYNC | ON—SYNC mode, | OFF – No Sync mode |
| DIP3---- | DIP3 | Spare for V4.2 and before | |
| DIP4---- | CODE | ON—Encoder control M1 only, | OFF – limit control |
| DIP5---- | LKPS | ON—Lock Pulse Output, | OFF – Lock Presence Output |
| DIP6---- | NOLS | ON—N/O limit switch, | OFF – N/C limit switch |
| DIP7---- | PECL | ON—PE trig Auto Close, | OFF – No PE trig Auto close |
| DIP8---- | AUCL | ON—Auto Close Mode, | OFF – No Auto close |

3.3 Motor Force

If any motor current over current setting, both motors will stop in opening cycle or reopen in closing.

If gate(motor) already in low-speed section and nearly closed or opened, controller will not response the overload

3.4 Power input

12 or 24V AC power input. 12VAC for 12VDC motor, 24VAC for 24V DC motor

3.5 Battery Backup

12V battery --- 12VDC motor, 12VAC input.

24V battery --- 24VDC motor, 24VAC input.

Solar regulator output can be direct connected to this terminal if in case of solar application.

3.6 Motor output

M1: Motor 1 output. M2: Motor 2 output

3.7 Power output

Power out for accessories. About 14V----- 12VAC supply, about 26V-----24VAC supply

3.8 Timers setting

Push Buttons functions

Button	SET ON---Setting	SET OFF---Running	Note
OPN	Sync Delay Time	Open gate	
PED	Lock Pulse Time	Lock pulse Time	
CLS	PE Trig Close Time	PE Trig Close Time	

Controller Setting

SET	Auto Close Time	Auto Close Time	
-----	-----------------	-----------------	--

Set time settings

Turn SET on, red and green LED flashes a little fast alternatively.

Push and hold on OPN for **Sync Delay Time**

Push and hold on PED for **Lock Pulse Time**

Push and hold on CLS for **PE Trig Close Time**

Push and hold on STP for **Auto Close Time**

Factory setting

Timer	F/Setting	Step	Setting Method	Range
Sync Delay Time	2 sec.	0.1 sec.	SET on + OPN Button	0-25 sec.
Lock Pulse Time	2 sec.	0.1 sec.	SET on + PED Button	0-25 sec.
PE Auto close Time	2 sec.	0.1 sec.	SEC on + CLS Button	0-25 sec.
Auto Close Time	30 sec.	0.1 sec.	SET on + PRO Button	0-6553 sec.

To restore factory setting, turn power off and set DIP1 (SET) on, push and hold CLS button, then power on. While hold CLS button, set SET1 off and then release the CLS button. Now controller restored factory setting from memory.

Special settings

To get into Special Setting: Turn power off and set DIP1 (SET) on, push and hold CLS button, then power on. then release the CLS button. Now controller get into special setting mode

DIP1 On + Special setting.

OPN button---Motor Close Delay Time (Default same to Open Delay Time)

PED button---Spare, CLS button---Spare

OSC button---Spare

Then turn DIP1 off, setting finished

Special setting at the moment only uses OPN bottom to set Close Delay Time. Sometimes Motor Close Delay Time need to be different to Motor Open Delay Time. Reset Motor Open Delay Time will reset Motor Close Delay Time, but reset Motor Close Delay Time will not change Motor Open Delay Time.

MOTOR CONNECTION

4 Motor Connections

4.1 Two wires motor without limit switch

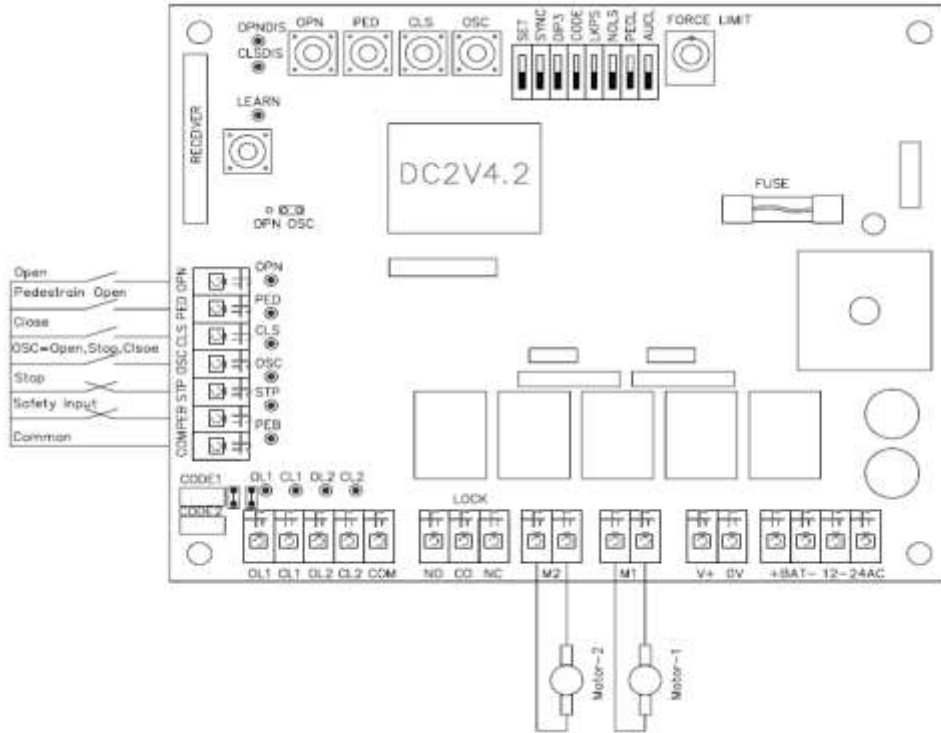

4.2 Five wires motor with N/C limit switch

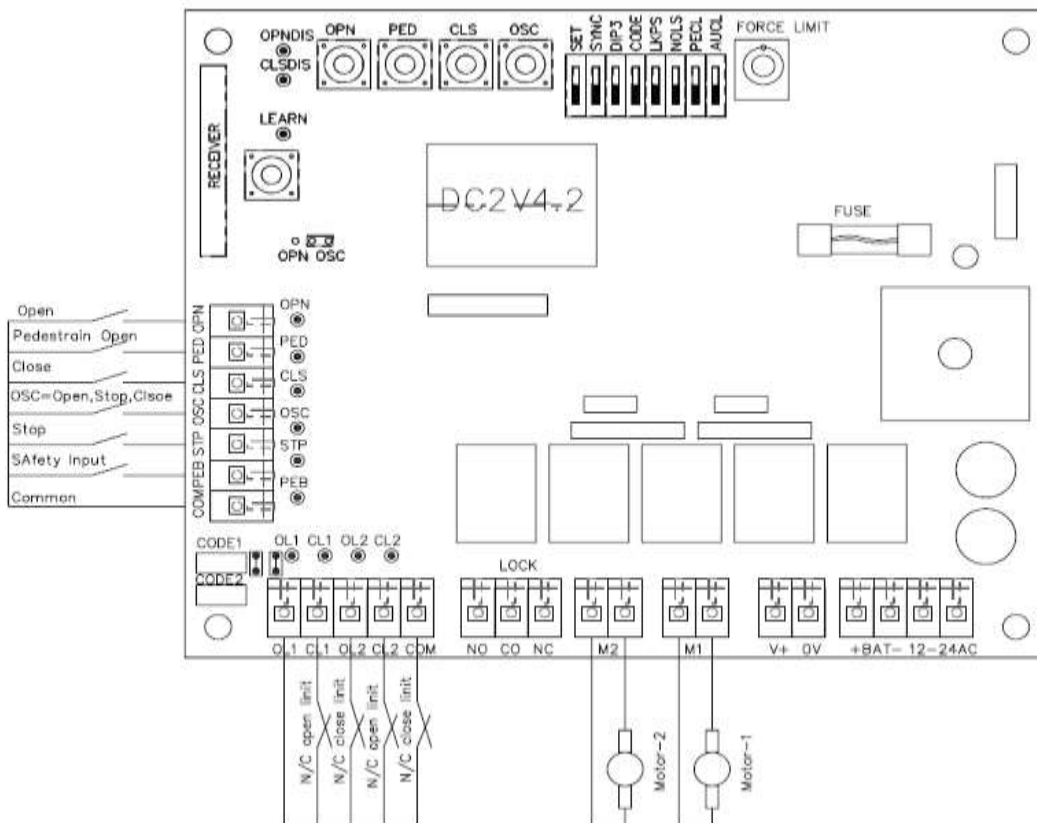

4.3 Sample of five wires with N/C limit

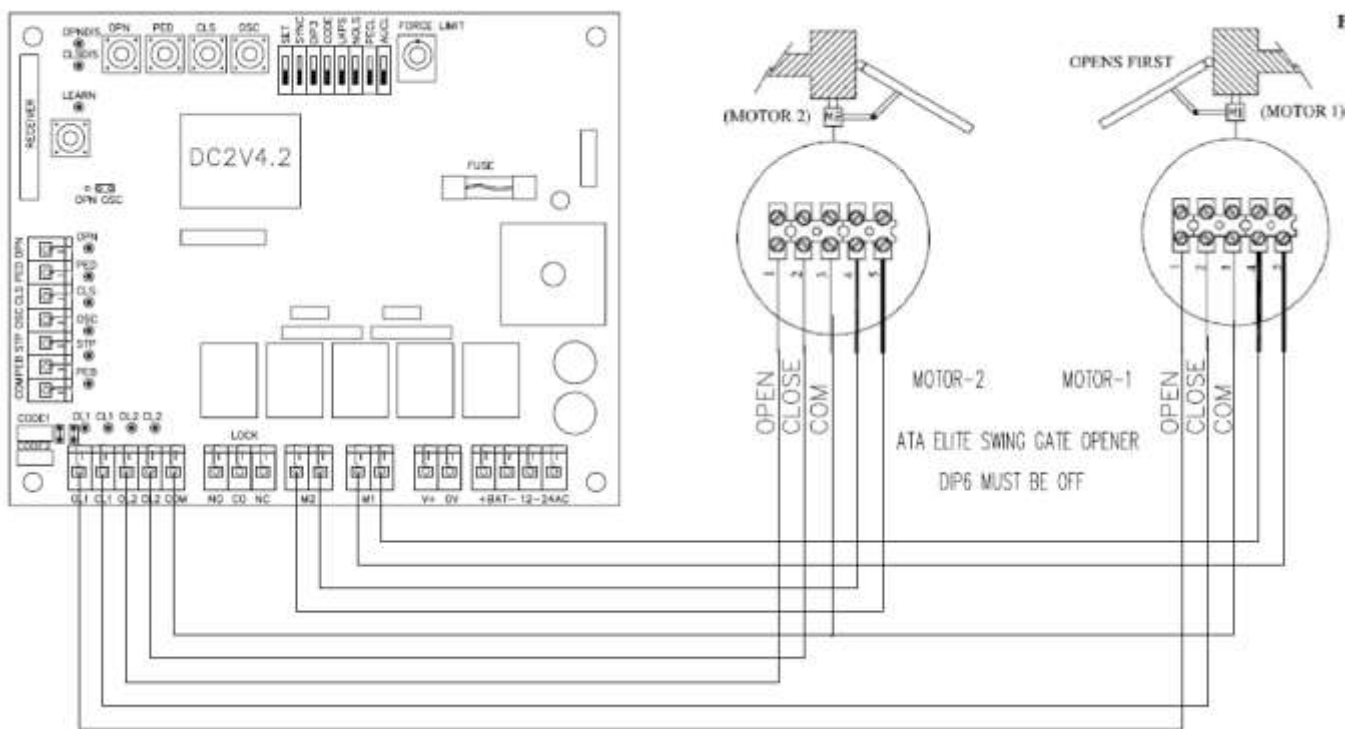

4.4 Step by step set up motor.

- a) Mounting and connect motor
- b) Disengage clutch and push two gates in middle position, then engage clutch. Power up, push OPN button, gate should open, if any gate goes close direction, switch motor two wires.
- c) Adjust limit switch (make sure DIP4 limit switch selection is matched to limit switch).
 - (1) If 5 wires system, turn power off and disengage clutch and setting limits switch. Move gate to closed position and adjust closed limit stop to touch the limit switch and this limit should connect to closed limit switch in put on control board. Open gate to opened position do the same things for opened limit switch.
 - (2) If 2 wires system with limit switch with diode, need keep power on, push remote, while gate is running (either open or close), using screw driver touch limit switch, so can find out which limit is for open or close. Turn power off, then disengage clutch, push gate and set up limit switch.
 - (3) If two wires system without limit switch, in this case, opened and closed mechanical stopper must be installed. Adjust motor force pot to suit actual gate power requirement.
- d) Power up, use remote or push button to operate gate. Controller will automatically learn soft stop positions. After two fully close and open cycles, auto-learn procedure finish.

TROUBLE SHOOTING GUIDE

5 Trouble shooting guide

5.1 General checking

Normally if installation is done properly, there would be trouble free. If in case of malfunction, please checking as following steps.

- 1) Check the DIP setting limit switch selection is right.
- 2) Gate status LED green (open) and red (close), one or both should be flashing depending on the gate position. If not flashing, please check the power supply and 12V DC output circuits if there is a short circuit.

5.2 Gate not open

- 1) Check the limits switch type selection if it is right.
- 2) Push button on the control board, if gate status green LED flashing and red LED off, please check motor fuse and motor.

5.3 Gate not close

- 1) Check the limits switch type selection if it is right
- 2) Check the DIP switches auto close mode selection if it is right.
- 3) Check control input. If one or more of OPN, PED, PEB input LED are on, which means access control system hold gate open.

5.4 Control board display right, but motor not run

- 1) Mot like is the motor protect fuse burnt. 5x20mm, 10A. that is caused motor jammed or wrong connection. Please check motor mechanism.