



DIGIWAY GATE MOTOR

Industry Slider P550-2



Specifications

- Built in encoder system, no limit switch required.
- 100% duty cycle three-phase 0.55 KW
- Variable speed inverter with 4 different speed.
- Intelligent controller with different operation model.
- High speed up to 700mm/sec
- Track or cantilever gates up to 1-tone.
- Galvanized sheet powder coat cabinet --- black
- P550-2 dimensions: 520Hx320Wx200D(mm)

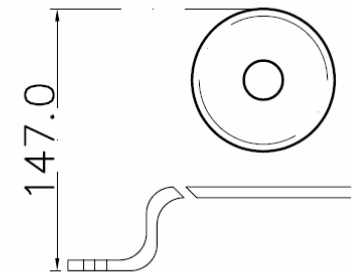
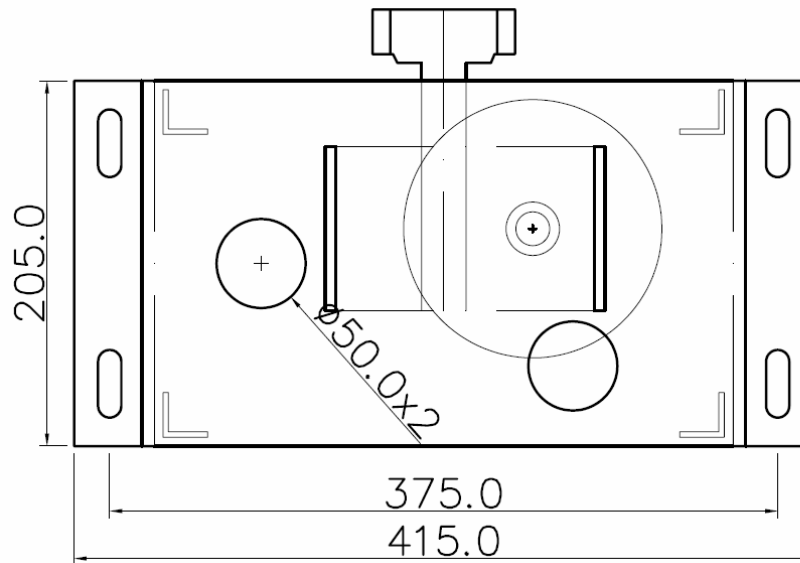

Digiway The better way

