

Sliding Gate Operator User's Manual

SL300

1. Products introduction

please read the instructions carefully before proceeding.

The operator contains Extra battery, transformer, control board and radio control.

In case of power of failure, the operator is powered by a 24Vdc, 4.0Ah, extra battery.

Intelligent charging system supplied.

MCU is supplied to control the gate operator.

Keypad / single button interface.

Photo beam safety beam interface.

User can select Auto-close feature

Soft start & soft stop.

Manual key release design for emergency purposes.

Gate operator has auto-reverse function, and the reverse power can change by user.

2. Important safety information

Carefully read and follow all safety precaution and warnings before attempting to install and use this automatic gate operator.

Make sure the Power supply(AC220V or AC110V) of operator is suitable for the power supply in your area.

3. Main technical parameters

<i>Unit Model</i>	<i>SL300DC</i>
<i>Power Supply</i>	<i>220VAC/110VAC</i>
<i>Maximum gate weight</i>	<i>300Kg</i>
<i>Maximum gate width</i>	<i>8m</i>
<i>Motor</i>	<i>24VDC 100W</i>
<i>Output torque</i>	<i>Max. 8N·m</i>
<i>Work duty</i>	<i>S₂ 30min</i>
<i>Limit switch</i>	<i>electronical Limit</i>
<i>Gate Move speed</i>	<i>13m/min</i>
<i>Remote control range</i>	<i>≥30 meters</i>
<i>extra remote control</i>	<i>20</i>
<i>Frequency</i>	<i>433.92 MHz</i>
<i>Noise</i>	<i>≤60 dB</i>
<i>Working temperature</i>	<i>-20°C ~ +50°C</i>

Extra Battery	24V 4.0Ah
---------------	-----------

4. Mechanical Installation

The SL300DC will handle gate weighting up to 300Kg and up to 8m if the proper installation procedures have been followed.

The SL300DC gate operator operates by forcing a drive rack by a drive gear. The entire configuration is shown in the diagram below. The gate operator must be installed on the inside of the gate.

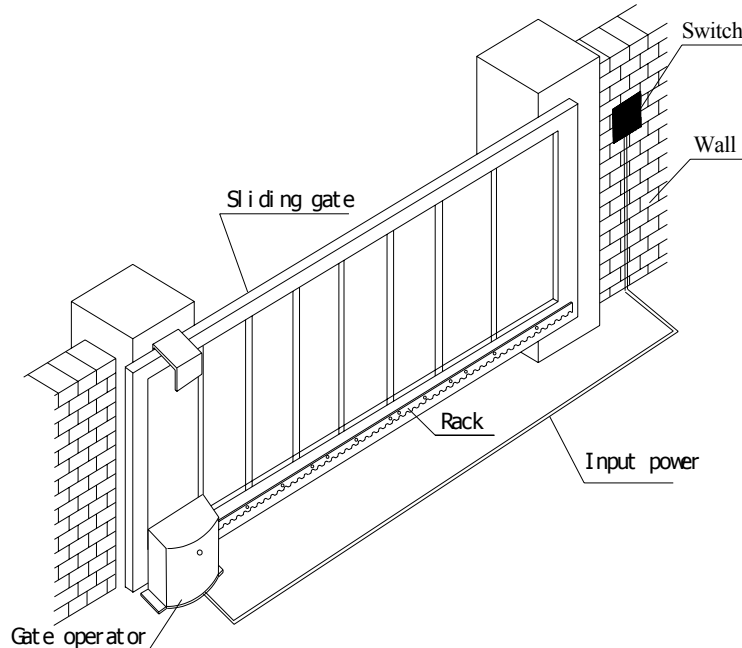

Fig.1

Gate preparation

Be sure the gate is properly installed and slides smoothly before installing the PY300DC sliding gate operator. The gate must be plumb, level, and move freely.

Conduit

In order to protect the wires, use PVC conduit for low voltage power cable and control wires. Conduit must be preset into the concrete when it is poured. Wires within the conduit shall be located or protected so that no damage can result from contact with any rough or sharp part.

Concrete pad

The base unit of the gate operator requires a concrete pad in order to maintain proper stability. The concrete pad should be approximately 400mm x 250mm x 200mm deep in order to provide for adequate weight and structure to insure proper stable installation.

Anchors (see Fig.2)

You can use anchor bolts, anchors, washers and nuts. These anchors must be set into the concrete when it is poured or you can use wedge anchors to fasten the operator.

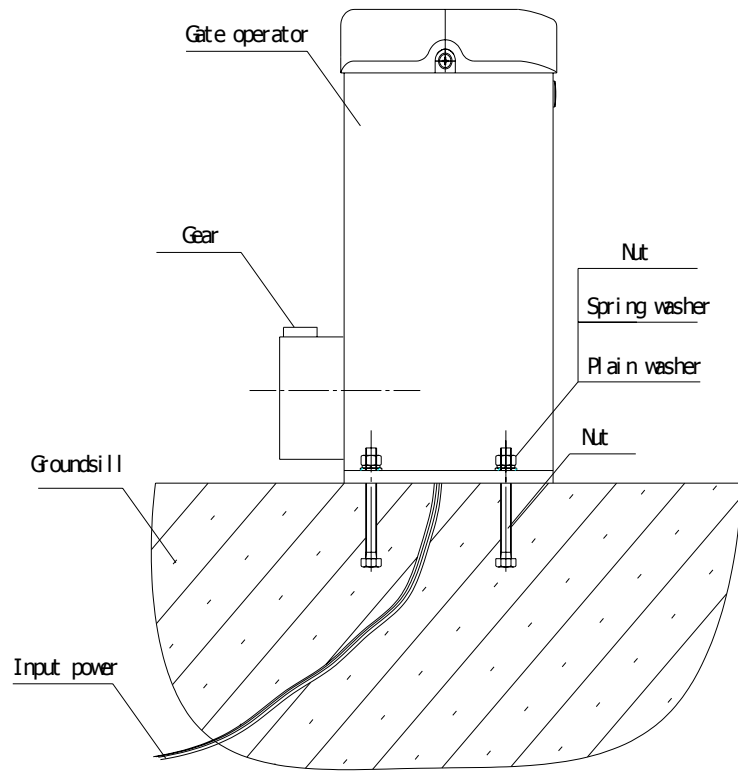

Fig.2

Operator base (see Fig.3)

After the concrete has hardened, mount the gate operator base to the concrete pad. Verify that the base is properly leveled.

Using bolts and washers mount the gate operator to the base and insert the cover. Check the operator and make sure it is lined up with the gate.

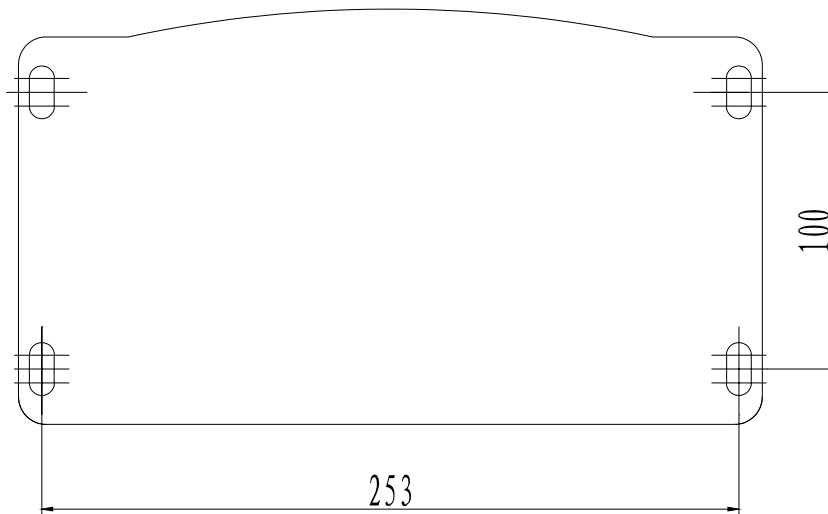

Fig.3

Installation of Rack

- Fix the three nuts (in the same package with rack) on the rack element.
- Lay the first piece of rack on the gear and weld the first nut on the gate.
- Move the gate manually, checking if the rack is resting on the gear, and weld the second and third nut.
- Bring another rack element near to the previous one. Move the gate manually and weld the three nuts as the first rack, thus proceeding until the gate is fully covered.
- When the rack has been installed, to ensure it meshes correctly with the gear.
- The space between rack and gear is about 0.5mm.

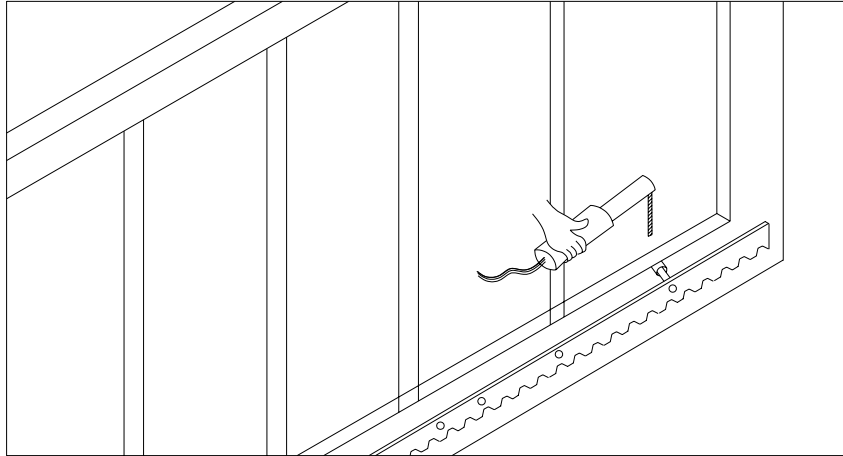

Fig.4

5. Adjustment

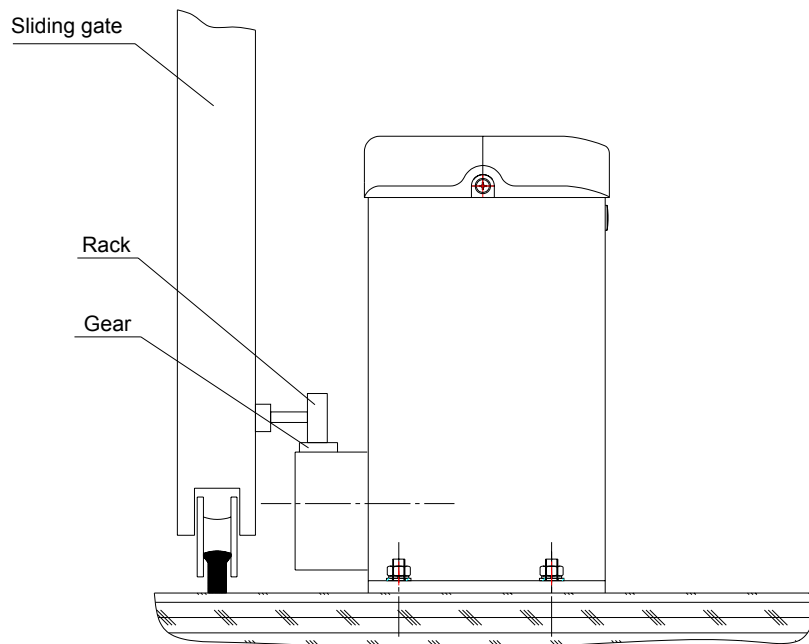

Fig.5

Manual operation

In case of power failure use manual release key to open or close gate manually, use the release key as follow:

- Fit the supplied key in the hole.
- Turn the key **clockwise** to release the clutch.
- Open and close the gate manually.
- After power-restored use the manual release key to tight the clutch by turning the key **counterclockwise** and resume normal operation.

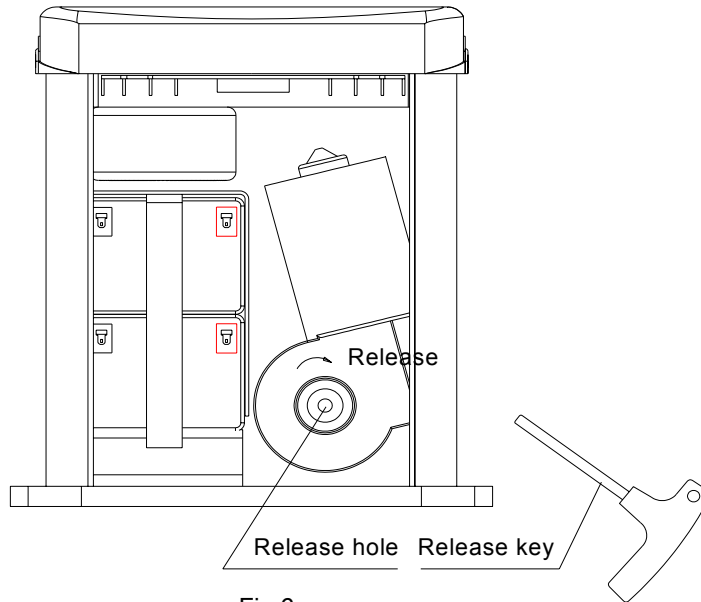

Fig.6

NOTE: The gate operator needed reset limit after re-tight the clutch by turning the key counterclockwise if the power failure and released by hand.

6. Wire Connecting

Connecting the battery

Plug the terminal of Extra battery in the control board.

NOTE:If you not use gate operator and power failure, please pull out the extra battery terminal.Fig.7

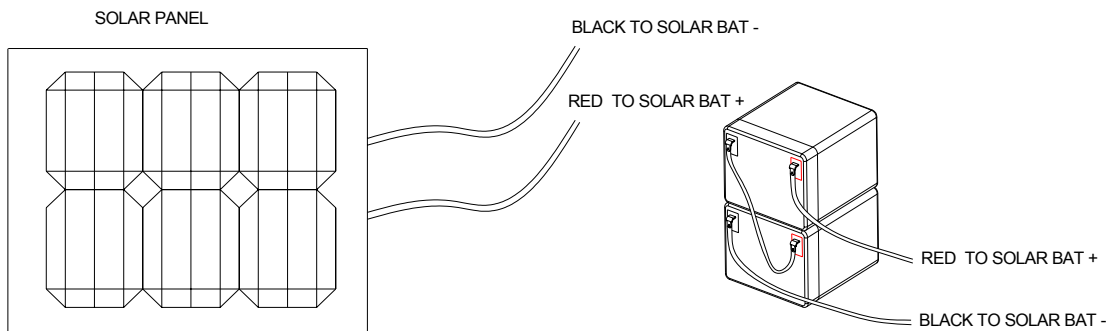

Fig.7

Connecting the motor

Connect motor wires to ‘M-’ and ‘M+’ of terminal block T1 (BLACK) and T2 (RED).

Connecting power wire

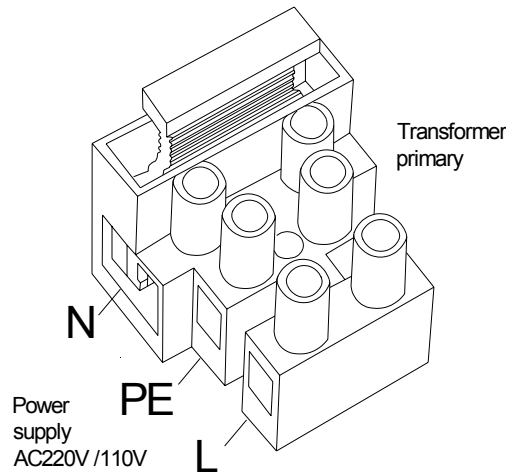

Fig.8

7.Electrical and control board

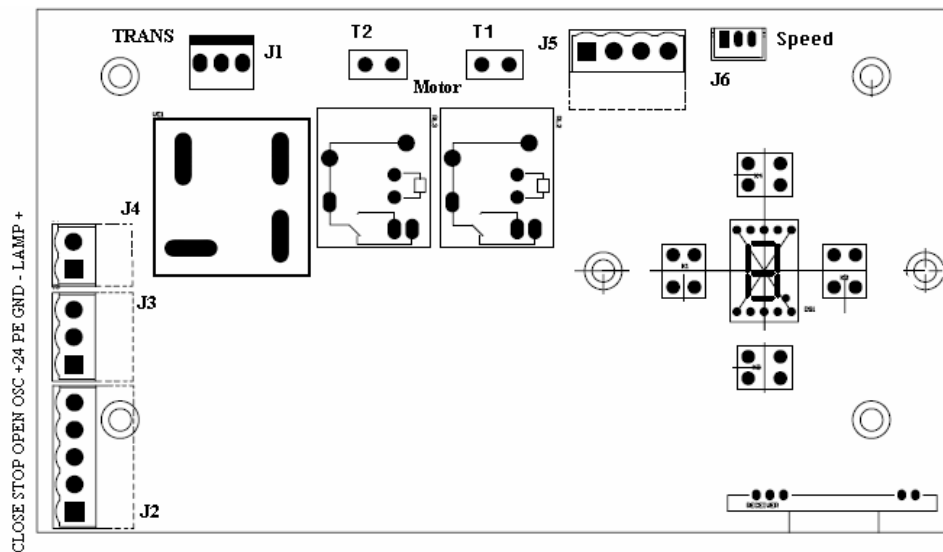

Fig.9

Motor: black wire to T1 and red wire to T2.

J1: transformer secondary(AC24V/3.3A)

external Push Button(J2,J3,J4):

Single Button(OSC and COM)

Three Button(K,G,T,and COM),

Photo beam(PE and COM)

Output DC power: 24 and GND

J5: solar panel(10W 27V) and charge Battery.

NOTE: Please put through the “J5”(Battery) terminal, if you need use the sliding gate operator.

8. Programming Process

SET button: Mode set and Confirm function

CODE button: Transmitter set and clear function

OPEN button: open door

CLOSE button: close door

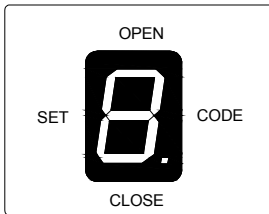

Fig.10

Adding extra transmitter (learn)

1. Press **CODE**, a dot is indicated on the LED display.
 2. Press the transmitter button which you want to use (button 1, 2, 3, 4), then press the same button again.
 3. The dot on the LED display will flash then turn off.
 4. '||' is indicated on the LED display, then the learning process is finished.
- Up to 20 transmitters may be used.

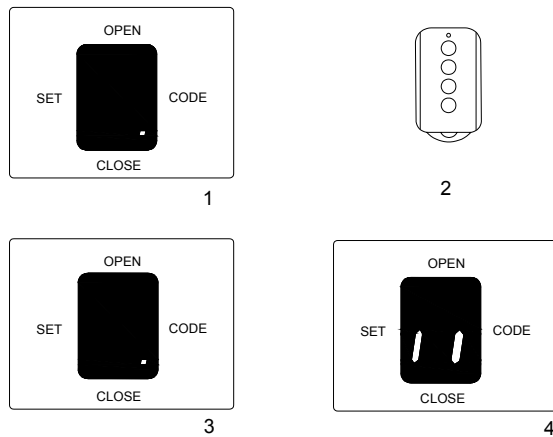

Fig.11

Erase transmitter

Press and hold **CODE** until 'C' flashes on the LED display. This indicates that all the transmitters have been erased completely.

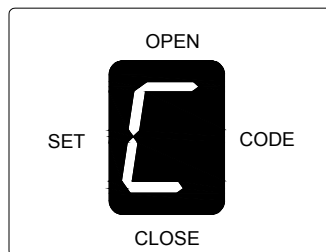

Fig.12

Set open and close positions

1. Press and hold **SET** until number '1' is indicated on the LED display.
2. Press and hold **OPEN** to set open position(now the door must be *OPEN*,, if not,please change the motor wire red and black), release the button until the door has reached the desired position. (You also can press **CLOSE** to move the door close, **OPEN** and **CLOSE** can be used to fine adjust the door position.)
3. Press the **SET** to confirm the open position, now number '2' is indicated on the LED display.
4. Press and hold **CLOSE** to set close position, release the button until the door has reached the desired position. (You also can press **OPEN** to move the door open, **OPEN** and **CLOSE** can be used to fine adjust the door position.)
5. Press the **SET** to confirm the close position.
6. The door will do a complete open and close cycle.

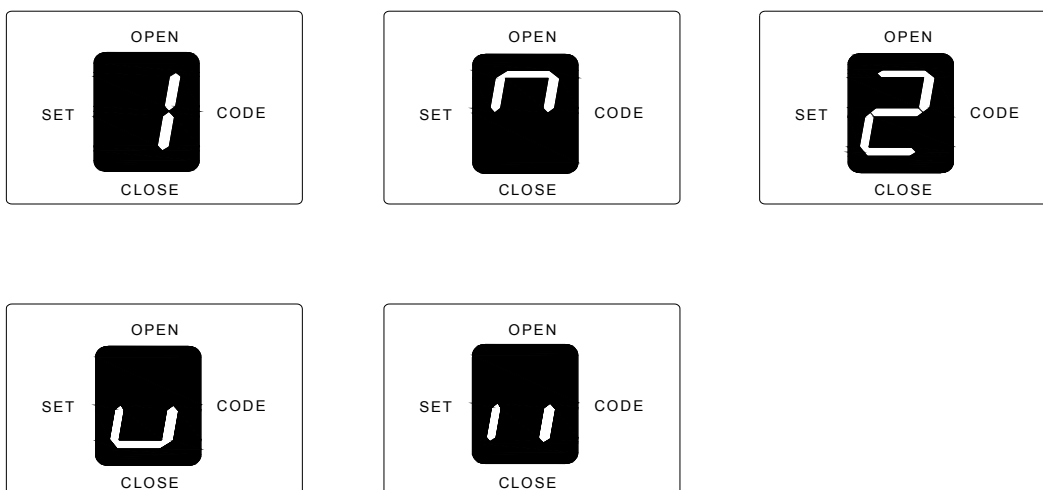
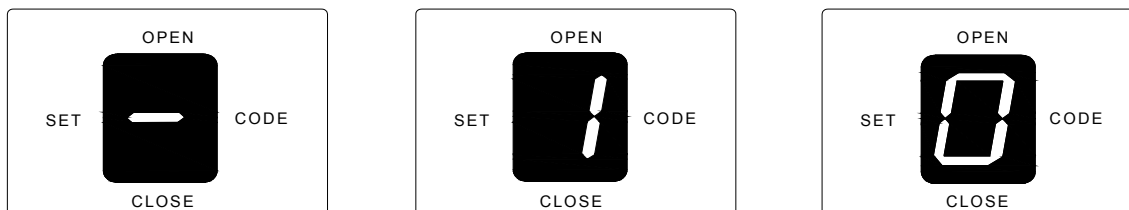

Fig.13

Automatic close (0~90 seconds adjustable)

1. Press and hold **OPEN** until '—' is indicated on the LED display.
2. Press **OPEN** to increase the auto close time, press **CLOSE** to decrease time.
3. Set timer to '0', the automatic close function will disable.
4. Press **SET** to confirm the setting.
5. Add 10 second per number

NOTE: Automatic close function is available only when the door is in fully opened position.



Setting obstruction force

If the door meet an obstruction during closing, it will stop and reverse about 15cm~20cm.

1. Press and hold **SET**. The LED will display number from '1' to '4', when the number '3' appears on the LED display, release the **SET**.
2. Press **OPEN** to increase the obstruction force, the maximum force is level 9. Press **CLOSE** to decrease force, the minimum force is level 1.
3. Press **SET** to confirm.

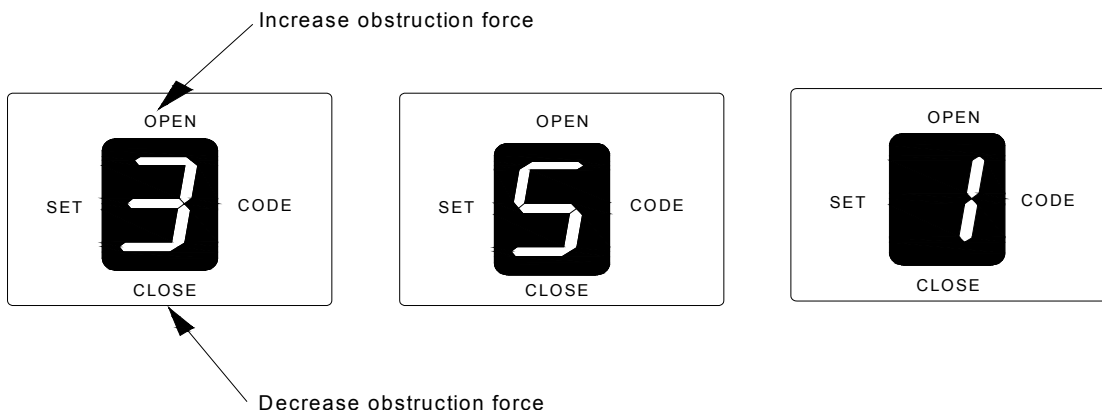

Fig.14

Photo beam:

Connect the photo beam follow Figure. The photo beam output signal must be N.C. signal.

Press and hold **close** until '—' is indicated on the LED display. Release the **close**, '11' will indicate on the LED display. Press **open**, 'H' will indicated on the LED display. Press **SET** to confirm. **Then Connect the photo beam follow the Figure.** (Note: When not using photo beam, please click the above action and set to "11" status)

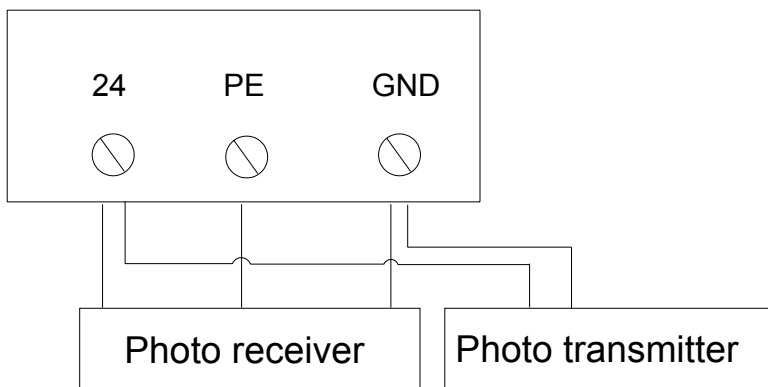

Fig.15

9. Maintenance

- Check the door once a month. The door should be carefully checked for balance. The door must be in good working order.
- The auto-reverse function should be regularly inspected, and adjusted if necessary. For service, call an experienced serviceman.

- We suggest for safety reasons, photocells be used on all gates.
- Disconnect from mains supply before replacing bulb.
- Be sure to read the entire manual before attempting to perform any installation or service to the door operator.
- Our company reserves the right to change the design and specification without prior notification.

10. Troubleshooting

Trouble	Possible causes	Solutions
The door fails to open and close. LED display does not light.	1. Power is OFF 2. Fuse burn	1. Make sure that power is ON. 2. Replace fuse.
The door can open, fails to close.	1. Infrared beam is obstructed. 2. Infrared photocell function is enable, but the photocell has not been installed.	1. Remove obstructions. 2. Make sure the infrared photocell function is disable.
Remote control does not work.	1. Battery level may be low, 2. Transmitter	1. Replace the battery inside the transmitter. 2. Re-program the transmitter.
The transmitter operating distance is too short.	Battery level may be low.	Replace battery.

11. Packing list

After receiving the gate operator, you should make an unpack-inspection, in which you should check whether the product was damaged. If you have any problem please contact our dealer. You should find the following items in our standard packing:

No.	Item	Quantity
1	PY300DC sliding gate operator	1
2	hand transmitter	2
3	Release key	1
4	User's manual	1